

Plug-in Door Chime Receiver

MODEL:
LA-203RWH

For use with these NuTone wireless products:
LA-203WH, LA-205WH, LA-206WH, LA-206TWH,
LA-207TWH (sold separately)

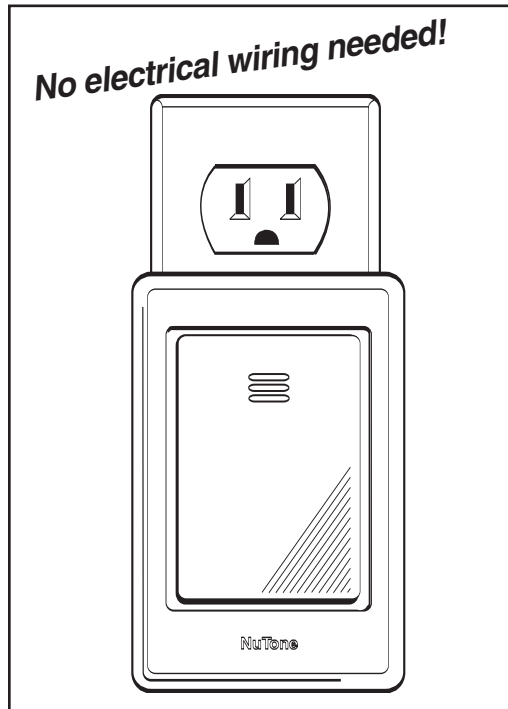

To install:

- Simply plug chime receiver into any standard electrical wall outlet within 100 feet of Pushbutton.
(Chime is powered by household current.)
- Chime will sound when Pushbutton is pressed.

NOTE: Chime Receiver will not work alone.

If you should encounter a problem.

PROBLEM	SOLUTION
1. Chime does not sound.	<ul style="list-style-type: none"> • Check position of battery (+/-) in Pushbutton. • Make sure Pushbutton is not located on a metal surface. • Check that outlet on Chime Receiver has power. • Check Pushbutton and Chime codes. These codes must match.
2. Chime is activated by another wireless device.	<ul style="list-style-type: none"> • Change the security code in the Pushbutton and Chime Receiver. These codes must match. (See detailed instructions below.)

CHANGING THE SECURITY CODE ON CHIME RECEIVER

To use the LA-203RWH Chime Receiver with your NuTone Wireless Chime, set code in this Chime Receiver to match code set in your Pushbutton. **Here's how:**

- Remove cover of Pushbutton by inserting screwdriver in the slot at the bottom of the Pushbutton and then gently rock the Pushbutton cover apart from the base. **(Figure 1)**
Locate vertical row of black jumpers on right side of Pushbutton. **(Figure 3 Detail)**
- Remove the screw from the access cover on back of Chime Receiver, then remove cover. **(Figure 2)**
- Set the code switches in the Chime Receiver to match the black jumpers in the Pushbutton. If a black jumper is in place, then the corresponding switch on the Chime Receiver must be set in the "ON" position. **(Figure 3)**
For example: if jumper #1 is in place, code switch #1 should be in the ON position.
- After setting the switches, replace the cover and screw on back of Chime Receiver.
- Replace Pushbutton cover.

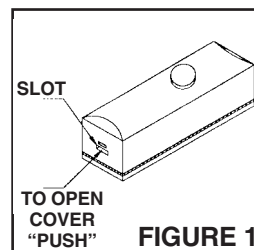
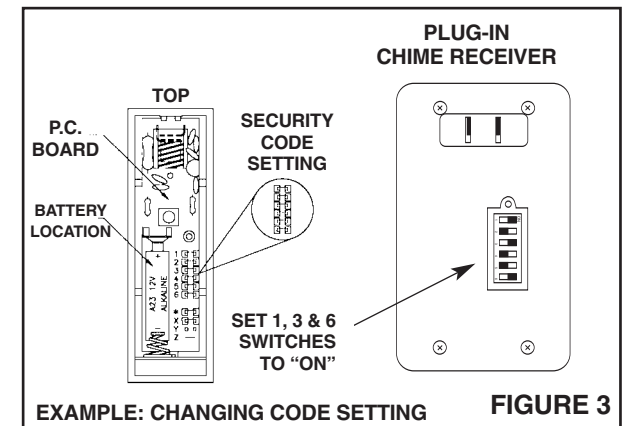

FIGURE 1



FIGURE 2



EXAMPLE: CHANGING CODE SETTING

FIGURE 3

NuTone®

One Year Limited Warranty

WARRANTY OWNER: NuTone warrants to the original consumer purchaser of its products that such products will be free from defects in materials or workmanship for a period of one (1) year from the date of original purchase. **THERE ARE NO OTHER WARRANTIES, EXPRESS OR IMPLIED, INCLUDING, BUT NOT LIMITED TO, IMPLIED WARRANTIES OF MERCHANTABILITY OR FITNESS FOR A PARTICULAR PURPOSE.**

During this one year period, NuTone will, at its option, repair or replace, without charge, any product or part which is found to be defective under normal use and service. **THIS WARRANTY DOES NOT EXTEND TO FLUORESCENT LAMP STARTERS OR TUBES, FILTERS, DUCT, ROOF CAPS, WALL CAPS AND OTHER ACCESSORIES FOR DUCTING.** This warranty does not cover (a) normal maintenance and service or (b) any products or parts which have been subject to misuse, negligence, accident, improper maintenance or repair (other than by NuTone), faulty installation or installation contrary to recommended installation instructions.

The duration of any implied warranty is limited to the one year period as specified for the express warranty. Some states do not allow limitation on how long an implied warranty lasts, so the above limitation may not apply to you.

NUTONE'S OBLIGATION TO REPAIR OR REPLACE, AT NUTONE'S OPTION, SHALL BE THE PURCHASER'S SOLE AND EXCLUSIVE REMEDY UNDER THIS WARRANTY. NUTONE SHALL NOT BE LIABLE FOR INCIDENTAL, CONSEQUENTIAL OR SPECIAL DAMAGES ARISING OUT OF OR IN CONNECTION WITH PRODUCT USE OR PERFORMANCE. Some states do not allow the exclusion or limitation of incidental or consequential damages, so the above limitation or exclusion may not apply to you. This warranty gives you specific legal rights, and you may also have other rights, which vary from state to state. This warranty supersedes all prior warranties.

WARRANTY SERVICE: To qualify for warranty service, you must (a) notify NuTone at the address stated below or telephone 1/800-543-8687, (b) give the model number and part identification and (c) describe the nature of any defect in the product or part. At the time of requesting warranty service, you must present evidence of the original purchase date.

Date of Installation _____ Builder or Installer _____

Model No. and Product Description _____

IF YOU NEED ASSISTANCE OR SERVICE:

For the location of your nearest NuTone Independent Authorized Service Center:
Residents of the contiguous United States Dial Free 1-800-543-8687
Please be prepared to provide:
Product model number • Date and Proof of purchase • The nature of the difficulty

Residents of Alaska or Hawaii should write to: NuTone Inc. Attn: Department of National Field Service, 4820 Red Bank Road, Cincinnati Ohio 45227-1599.

Residents of Canada should write to: Broan-NuTone Canada, 1140 Tristar Drive, Mississauga, Ontario, Canada L5T 1H9.

Rev. 01/2005

NuTone®

DIRECTIVES
D'INSTALLATION ET D'UTILISATION
LIRE ET CONSERVER CES DIRECTIVES

Récepteur de carillon enfichable

MODÈLE:

LA-203RWH

Pour les carillons sans fil série NuTone
LA-203WH, LA-205WH, LA-206WH, LA-206TWH,
LA-207TWH (vendu séparément)

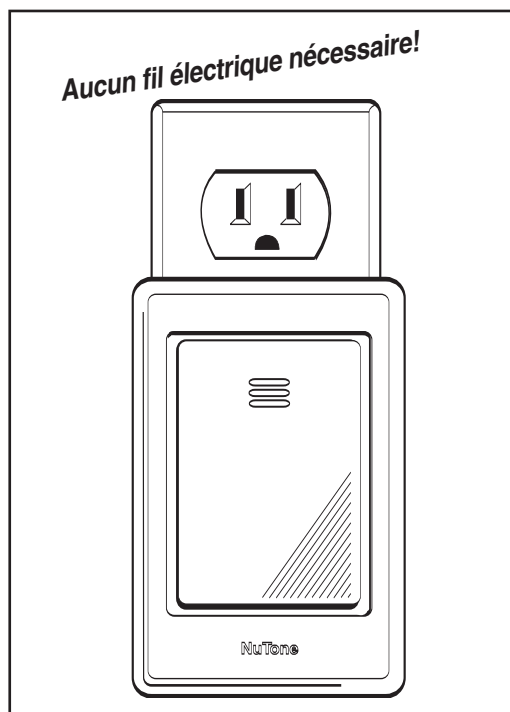

Installation:

1. Brancher simplement le récepteur du carillon dans une prise de courant murale standard située dans un rayon de 100 pieds (30 mètres) du bouton-poussoir. (Le carillon est alimenté par le courant secteur.)
2. Le carillon résonne et la lumière stroboscopique clignote lorsqu'on appuie sur le bouton-poussoir.

NOTE: Le récepteur de carillon ne fonctionne pas s'il est utilisé seul.

En cas de problème:

PROBLÈME	SOLUTION
1. Le carillon ne sonne pas.	<ul style="list-style-type: none">• Vérifier la position de la pile (+/-) du bouton-poussoir.• S'assurer que le bouton-poussoir n'est pas situé sur une surface métallique.• S'assurer que la prise du récepteur est bien alimentée.• Vérifier les codes de sécurité du bouton-poussoir et du récepteur. Ces codes doivent être identiques.
2. Le carillon est déclenché par un autre appareil sans fil.	<ul style="list-style-type: none">• Modifier les codes de sécurité du bouton-poussoir et du récepteur. Ces codes doivent être identiques. (Voir les directives détaillées plus loin.)

MODIFICATION DU CODE DE SÉCURITÉ DU RÉCEPTEUR

Pour utiliser le récepteur de carillon LA-204RWH avec votre carillon sans fil NuTone, vous devez régler le code de sécurité du récepteur de façon qu'il soit identique à celui du bouton-poussoir. **Voici comment procéder:**

1. Retirer le couvercle du bouton-poussoir en insérant la pointe d'un tournevis dans la fente au bas du réceptacle, puis en faisant doucement pivoter le couvercle sur le socle (**Figure 1**). Repérer la ligne verticale de cavaliers noirs du côté droit du bouton-poussoir (**détails de la Figure 3**).
2. Retirer la vis du couvercle situé à l'arrière du récepteur, puis enlever le couvercle (**Figure 2**).
3. Régler les commutateurs du récepteur de façon qu'ils correspondent aux cavaliers du bouton-poussoir. Si un cavalier noir est en place dans le bouton-poussoir, le commutateur du récepteur qui y correspond doit être à ON. (**Figure 3**)
Par exemple, si le cavalier no. 1 est en place, le commutateur no. 1 doit être à ON.
4. Après avoir réglé les commutateurs, remettre le couvercle en place au moyen de la vis.
5. Remettre le couvercle du bouton-poussoir.

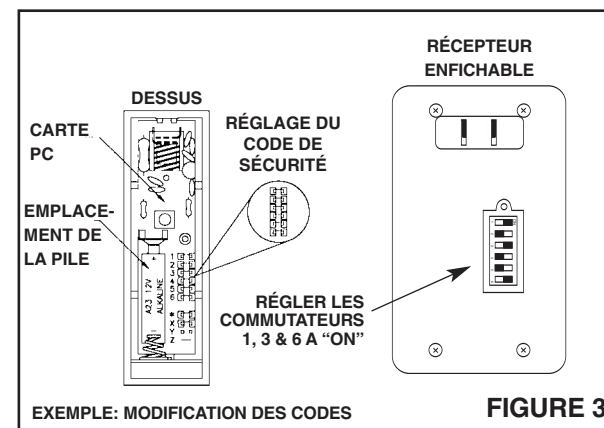
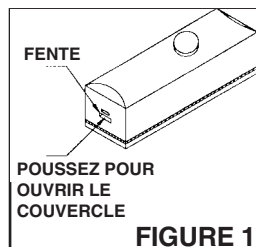

Les caractéristiques du produit peuvent être modifiées sans préavis.
1140 Tristar Drive, Mississauga, Ontario, Canada L5T 1H9
Imprimé en Chine

NuTone®

INSTRUCCIONES PARA
LA INSTALACIÓN Y OPERACIÓN
¡LEA Y GUARDE ESTAS INSTRUCCIONES!

Receptor de campana con luz

MODELO:
LA-203RWH

Para ser usado con las campanas inalámbricas
NuTone modelos LA-203WH, LA-205WH, LA-206WH,
LA-206TWH, LA-207TWH (se venden por separado)

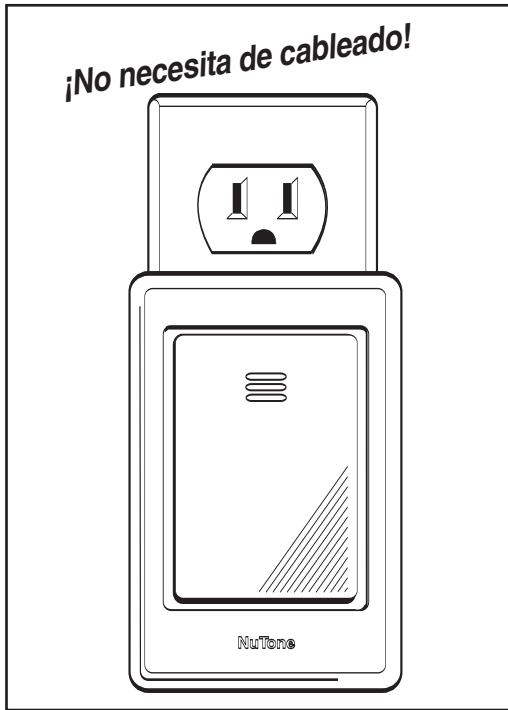

PARA INSTALAR:

1. Simplemente enchufe el receptor de la campana en cualquier tomacorriente de pared que se encuentre a un máximo de 100 pies (30 metros) del pulsador. (La campana funciona con la electricidad de su hogar.)
2. Al accionarse el pulsador la campana sonará y la luz estroboscópica emitirá destellos.

NOTA: El receptor de campana no funciona sola.

Si ocurre un problema:

PROBLEMA	SOLUCION
1. La campana no suena.	<ul style="list-style-type: none">• Revise las pilas y la polaridad (+/-) en el pulsador.• Verifique que el pulsador no esté sobre una superficie metálica.• Verifique que haya electricidad en el tomacorriente del receptor de campana.• Revise los códigos de seguridad del pulsador y el receptor de campana. Estos códigos deben coincidir.
2. La campana se activa con otro artefacto inalámbrico.	<ul style="list-style-type: none">• Cambie los códigos de seguridad del pulsador y el receptor de campana. Estos códigos deben coincidir. (Vea las instrucciones detalladas más abajo.)

COMO CAMBIAR EL CODIGO DE SEGURIDAD DEL RECEPTOR DE CAMPANA

Para poder usar el receptor de campana LA-204RWH con su campana inalámbrica, debe programar el código del receptor de campana para que coincida con el código del pulsador. **Esto se logra así:**

1. Retire la cubierta del pulsador insertando la punta de un destornillador en la ranura ubicada en la parte inferior de la misma. Con un ligero movimiento de vaivén separe la cubierta del pulsador de la base (**Figura 1**). Observe la fila de puentes negros que se encuentran en el lado derecho del pulsador (**Detalles en la Figura 3**).
2. Retire el tornillo de la cubierta posterior del receptor de campana y luego retire la cubierta (**Figura 2**).
3. Ajuste los interruptores de códigos del receptor de campana para que coincidan con los puentes negros instalados en el pulsador. Si un puente negro se encuentra en posición, su interruptor correspondiente en el receptor de campana debe estar en la posición "ON". (**Figura 3**)

Por ejemplo, si se ha instalado el puente no. 1, el interruptor no. 1 debe colocarse en la posición "ON".

4. Al terminar de ajustar los interruptores vuelva a colocar la cubierta en la parte posterior del receptor de campana y a torníllela.
5. Vuelva a colocar la cubierta del pulsador.



FIGURA 1



FIGURA 2

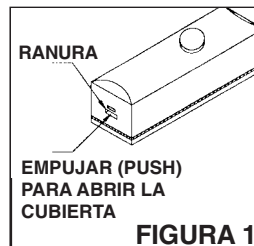
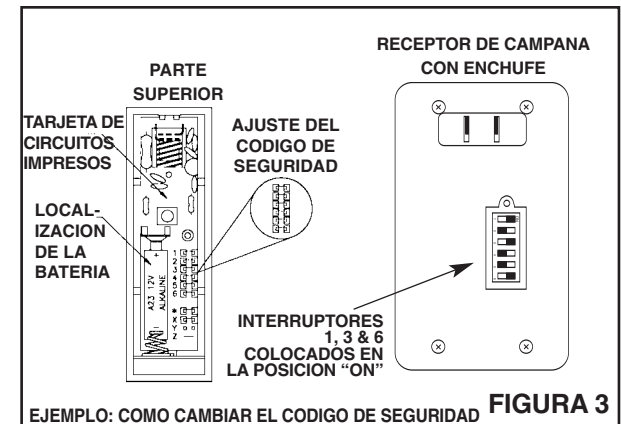

FIGURA 3

Las especificaciones del producto se encuentran sujetas a cambios sin previo aviso.
4820 Red Bank Road, Cincinnati, Ohio 45227
Impreso en China,

PARA COLOCAR ESTE PRODUCTO, VISITE WWW.NUTONE.COM